

Yale[®] YK[™]

ELECTRIC WIRE ROPE HOISTS



COLUMBUS MCKINNON CORPORATION

For more than a century, Columbus McKinnon has manufactured and supplied high-quality, high-performing hoists to customers for everything from mining operations to metals production. Drawing on this expertise and the technology of **our well-known Yale® and Magnetek® brands**, we designed and built the Yale YK™ electric wire rope hoist for optimal performance, reliability, and long life.

We've made customization easy. The Yale YK is available with a variety of capacities, lifts, and configurations that can be customized with optional features to meet environmental conditions. These options, such as spark-resistant wheels for hazardous atmospheres and rain covers for outdoor use, can be easily specified through the use of our online Compass™ configurator. Yale YK hoists are also available in complete crane kit solutions for quick and easy assembly and installation. YK hoists with our most commonly requested options ship fast from our facility in Wadesboro, NC, so you won't need to sacrifice features for short lead times.

Working together with our **network of authorized, crane-builder partners**, Columbus McKinnon provides you with the lifting solutions you need when you need them. We are here to support you before, during, and after the sale with a team of knowledgeable application and product specialists, responsive customer service teams, and professional trainers.



Yale[®] YK[™]

ELECTRIC WIRE ROPE HOISTS

WHAT DOES THE YALE YK BRING TO YOUR APPLICATION?

When you need quality and performance in a wire rope hoist, turn to the **Yale YK from Columbus McKinnon**. The Yale YK delivers the industry-leading technology and safety you need for your lifting applications in a compact, easy-to-maintain design. Precision engineered, these hoists are built for reliable operation, high efficiency, and long service life and are competitively priced for the U.S. market. Operators, crane manufacturers, and system manufacturers can benefit from the hoist's modular system that allows for configuration of the hoist and crane system to meet exact application needs. Complete with a low-headroom trolley, the Yale YK is ideal for applications with space limitations.

WIDE RANGE OF CAPACITIES AND LIFTS

Monorail units up to 30 tons and top-running, double-girder units up to 55 tons. Standard lifts up to 131 ft. Metric rated models also available.

FLEXIBLE CONFIGURATIONS

Hoists can be configured to your unique application needs. Available in 5 frame sizes with 16 load capacity variants.

SHORT LEAD TIMES

You'll get the high-quality product you need, fast. Assembled in Wadesboro, North Carolina, our most commonly requested models feature short lead times to meet tight deadlines.

COMPACT DESIGN

Exceptionally short approach allows for optimum use of work area when space is limited. Paddle limit switch allows for lowest headroom possible while maintaining safe operation.* Low-headroom monorail units are extremely compact due to U-shape design.

LOW MAINTENANCE

High-quality components designed for safety and longevity, providing you with minimal downtime and a low total cost of ownership. Local availability of common spare parts means that your products can be serviced quickly, helping to reduce downtime.

EXTENSIVE SAFETY FEATURES

Standard safety features include paddle limit switch*, adjustable geared limit switch, motor temperature control, and overload protection.

SMOOTH OPERATION

With an integrated motor management module and flywheel trolley motors, the YK features extremely smooth starting and braking with controlled starts and stops for extended brake life.

RELIABLE PERFORMANCE IN HEAVY-DUTY APPLICATIONS

Hoists available with H3, H4, and H4+ duty cycles.

COMPLIANCE WITH INDUSTRY STANDARDS

Hoists meet CMAA and HMI standards. CSA labeled. Explosion-protected models available in compliance with NEC guidelines.

*Currently, paddle limit switch is standard on monorail units with flange widths less than 12" (300mm)



MODELS AND TROLLEY CONFIGURATIONS

The YK wire rope hoist is available with a variety of rope drum and trolley options, providing flexibility and versatility in any application. Whether you need a base-mount, top-running double-girder, or low-headroom monorail model, there is a YK hoist to meet your needs. Trolleys are equipped with two-speed travel motors as standard. Other speeds, as well as variable frequency drives, are available as options.

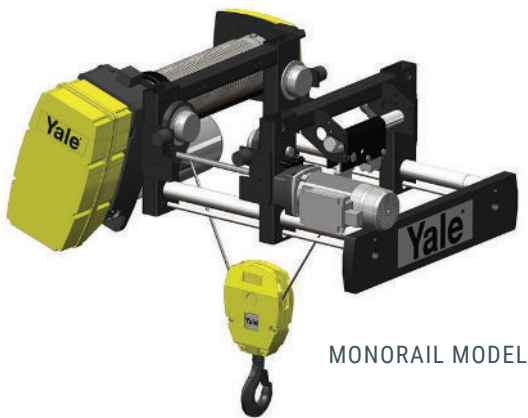

MONORAIL MODEL

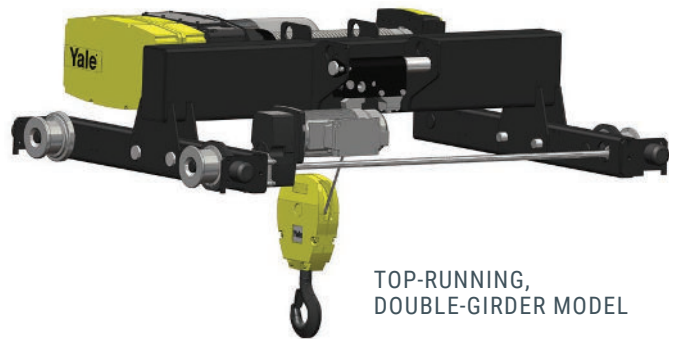

TOP-RUNNING,
DOUBLE-GIRDER MODEL

SINGLE-GROOVED ROPE DRUM
2-part single or 4-part single reeving is available, depending on the application.

Standard reeving

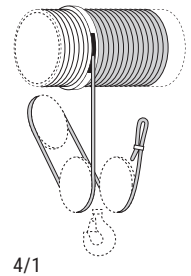
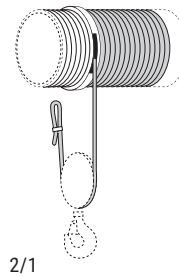
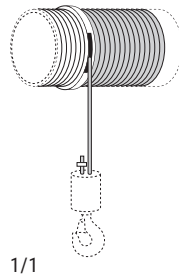

DOUBLE-GROOVED ROPE DRUM
If true vertical lift is required, we recommend a double-grooved rope drum (right-/left-hand thread). Available in base-mount or trolley configurations. Models with double-grooved rope drums ship from Germany.

True vertical lift

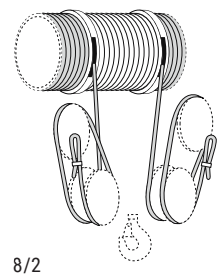
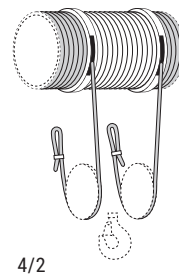
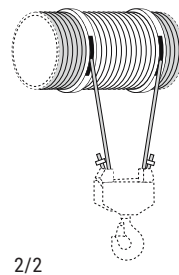

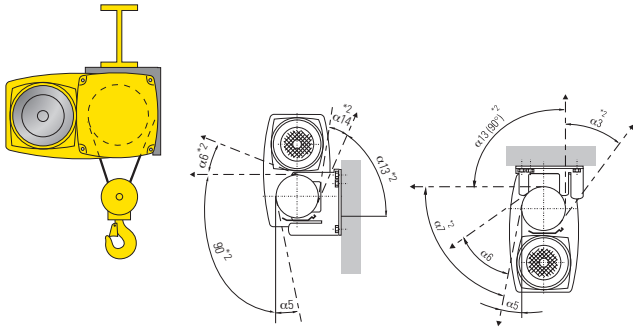

BASE-MOUNT

Can be used as stationary hoisting or towing equipment, for example in systems manufacturing. The rope lead-off angle, the hoist mounting, and the mounting position of the hoist motor can be adjusted as needed. Available for 1-55 ton capacities.

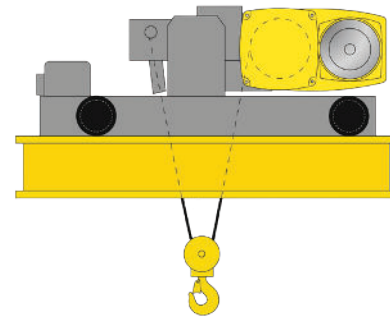

TOP-RUNNING, DOUBLE-GIRDER

Extremely compact with minimal hook approach and headroom dimensions. Flexible design ensures all four wheels are in contact with the girder. Available for 1-55 ton capacities.

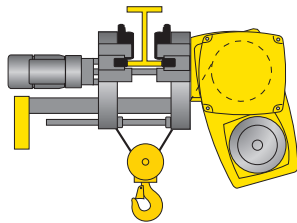

LOW-HEADROOM MONORAIL (LH)

Low-headroom monorail trolley is used on monorail runways and single-girder overhead traveling cranes. Trolley is easily adjustable for different beam sizes and comes standard with two speed trolley. Available for 1-15 ton capacities.

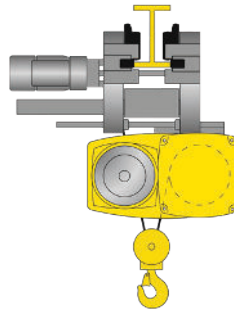

STANDARD HEADROOM MONORAIL (SH)

Specially designed for small clearances, the monorail trolley has a narrow width. It is used on monorail runways and single-girder overhead traveling cranes. Available for 20-30 ton capacities.

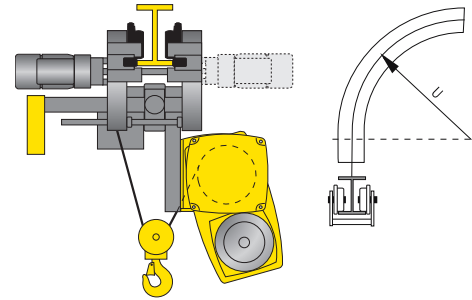

STANDARD HEADROOM SWIVEL (SW)

The standard headroom swivel trolley is designed for applications that require frequent travel around bends and narrow radii. Depending on the radius of the bend, runway flange width, or application, the trolley is equipped with one or two travel motors. Available for capacities up to 30 tons. Models with standard headroom swivel trolleys ship from Germany.

- Standard
- Available as engineered to order

Type	Load Capacity up to [tons]	Base-Mount Trolley	Top-Running Double-Girder Trolley	Monorail Trolleys		
				LH	SH	SW
YK A	3	●	●	●	●	●
YK B	7.5	●	●	●	●	●
YK C	10	●	●	●	●	●
YK D	15	●	●	●	●	●
YK E	30	●	●	●	●	●
YK F	30	●	●	●	●	●
YK G	55	●	●	N/A	N/A	N/A

THE ANATOMY OF THE YALE YK WIRE ROPE HOIST

You can work with confidence knowing the technology behind the Yale YK is designed to the highest industry standards. Working together, these low-maintenance components provide best-in-class performance, high efficiency, and long service life for any application.

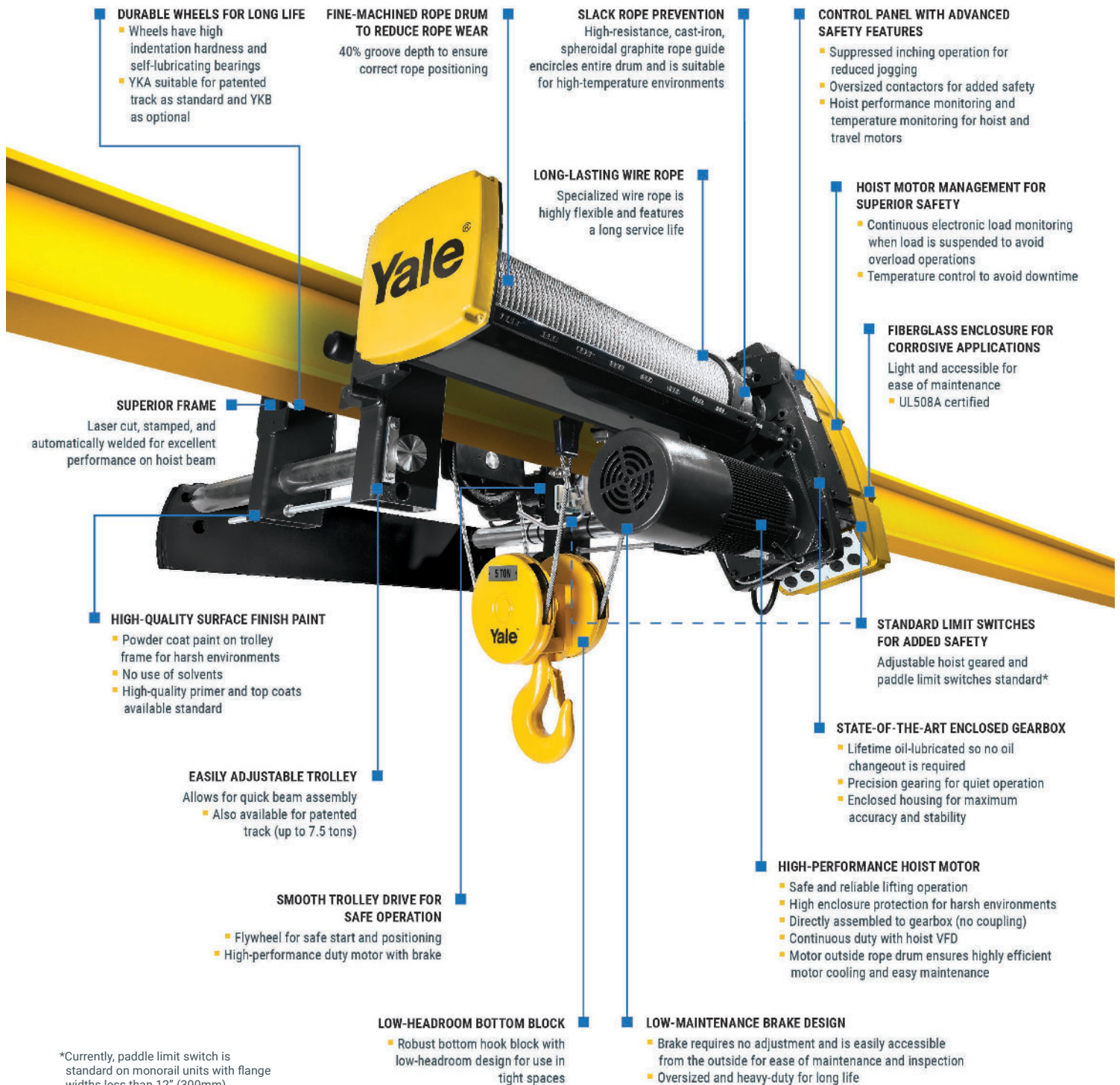

DURABLE WHEELS FOR LONG LIFE

- Wheels have high indentation hardness and self-lubricating bearings
- YKA suitable for patented track as standard and YKB as optional

FINE-MACHINED ROPE DRUM TO REDUCE ROPE WEAR

40% groove depth to ensure correct rope positioning

SLACK ROPE PREVENTION

High-resistance, cast-iron, spheroidal graphite rope guide encircles entire drum and is suitable for high-temperature environments

CONTROL PANEL WITH ADVANCED SAFETY FEATURES

- Suppressed inching operation for reduced jogging
- Oversized contactors for added safety
- Hoist performance monitoring and temperature monitoring for hoist and travel motors

LONG-LASTING WIRE ROPE

Specialized wire rope is highly flexible and features a long service life

HOIST MOTOR MANAGEMENT FOR SUPERIOR SAFETY

- Continuous electronic load monitoring when load is suspended to avoid overload operations
- Temperature control to avoid downtime

FIBERGLASS ENCLOSURE FOR CORROSIVE APPLICATIONS

Light and accessible for ease of maintenance

- UL508A certified

SUPERIOR FRAME

Laser cut, stamped, and automatically welded for excellent performance on hoist beam

HIGH-QUALITY SURFACE FINISH PAINT

- Powder coat paint on trolley frame for harsh environments
- No use of solvents
- High-quality primer and top coats available standard

STANDARD LIMIT SWITCHES FOR ADDED SAFETY

Adjustable hoist geared and paddle limit switches standard*

EASILY ADJUSTABLE TROLLEY

Allows for quick beam assembly

- Also available for patented track (up to 7.5 tons)

STATE-OF-THE-ART ENCLOSED GEARBOX

- Lifetime oil-lubricated so no oil changeout is required
- Precision gearing for quiet operation
- Enclosed housing for maximum accuracy and stability

SMOOTH TROLLEY DRIVE FOR SAFE OPERATION

- Flywheel for safe start and positioning
- High-performance duty motor with brake

HIGH-PERFORMANCE HOIST MOTOR

- Safe and reliable lifting operation
- High enclosure protection for harsh environments
- Directly assembled to gearbox (no coupling)
- Continuous duty with hoist VFD
- Motor outside rope drum ensures highly efficient motor cooling and easy maintenance

LOW-HEADROOM BOTTOM BLOCK

- Robust bottom hook block with low-headroom design for use in tight spaces

LOW-MAINTENANCE BRAKE DESIGN

- Brake requires no adjustment and is easily accessible from the outside for ease of maintenance and inspection
- Oversized and heavy-duty for long life

*Currently, paddle limit switch is standard on monorail units with flange widths less than 12" (300mm)



INTELLIGENCE COMES STANDARD

Combining reliable, high-tech control and monitoring technology with the Yale YK's industry-leading design creates a one-of-a-kind, intelligent hoist for all your lifting applications. **The Yale YK comes standard with SLE/SMC control and motor management.** This system monitors the temperature of the hoist and travel motor to prevent overheating, while also monitoring the overall condition of the hoist to aid in preventative maintenance planning. The SLE/SMC also suppresses hoist inching operation to reduce wear and tear on the brake.

Optional on Yale YK hoists, **Magnetek IMPULSE® Variable Frequency Drives** continuously monitor many environmental and functional components of a hoist, such as motor temperature, end of travel and slow down limits, brake functionality, motor speed, and more. The drives also maintain safe functional thresholds, which decreases mechanical fatigue and increases reliability and uptime.

The functionality of the YK hoist can also be integrated with a variety of Magnetek-brand technology systems to provide hoist synchronization, anti-sway control, and faster lifting speeds when the hook is not under load. The YK can also be combined with our **Intelli-Crane™ family of automated systems**, including Intelli-Protect™ No-Fly Zone Technology and Intelli-Lift™ Off-Center Pick, Snag Detection and Correction.

TRAINING & AFTERMARKET SUPPORT

Columbus McKinnon and its network of authorized Channel Partners are committed to supporting you long after the sale. Whether you need replacement parts for your hoists, quick response on a warranty claim, or simply have a question about the operation or maintenance of your hoist, **we are here to help.**

We are dedicated to promoting the safe and efficient use of overhead cranes, hoists, and rigging equipment to keep your business running and increase your workers' safety. With a team of expert trainers, comprehensive and challenging curriculum, and state-of-the-art training centers, we bring you professionally developed courses that highlight safe operation and installation as well as accurate and timely product maintenance.

- Overhead Crane & Hoist Inspection Certification
- Overhead Crane & Hoist Frequent Inspection
- Rigging & Crane Operator Safety Training
- Static Stepless Crane Controls Training
- IMPULSE® AC Drive Training
- OmniPulse™ /MagnePulse™ DC Drive Training
- Radio Remote Control Training
- Application-specific training available upon request

For more information on our training programs, visit training.cmworks.com.



CRANE SOLUTIONS



MAGNETEK

Yale



UNIFIED

WWW.COLUMBUSMCKINNON.COM

Yale[®]

USA p: 800.888.0985

p: 716.689.5400

f: 716.689.5644

CAN p: 877.264.6478

f: 877.264.6477

WIREROPEAPPLICATIONS@CMWORKS.COM